

# DIGITAL COATING THICKNESS GAUGE ( F & NF TYPE)

## CM-8856

ALL RIGHTS RESERVED

### 3.FRONT PANEL DESCRIPTIONS

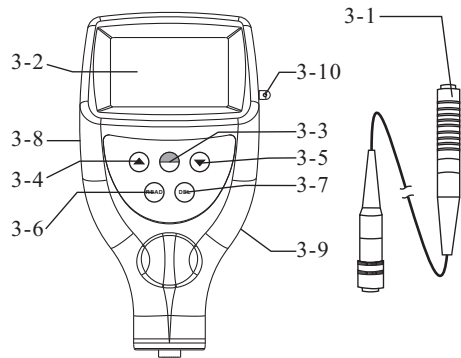

Fig. 1

- 3-1 Probes Inbuilt
- 3-2 Display
- 3-3 Power/Zero Key
- 3-4 Plus Key
- 3-5 Minus Key
- 3-6 Reading Key
- 3-7 Deleting Key
- 3-8 Jack for RS232C
- 3-9 Battery cover
- 3-10 Wrist Ring

### 1.FEATURES

- \* It meets the standards of both ISO2178 and ISO 2361 as well as DIN, ASTM and BS. It can be used both in the laboratory and in harsh field conditions.
- \* The F probes measure the thickness of non-magnetic materials (e.g. paint, plastic, porcelain enamel, copper, zinc, aluminum, chrome etc.) on magnetic materials (e.g. iron, nickel etc.). often used to measure the thickness of galvanizing layer, lacquer layer, porcelain enamel layer, phosphide layer, copper tile, aluminum tile, some alloy tile, paper etc.
- \* The N probes measure the thickness of non-magnetic coatings on non-magnetic metals. It is used on anodizing, varnish, paint, enamel, plastic coatings, powder, etc. applied to aluminum, brass, non-magnetic stainless steel, etc.
- \* Automatic substrate recognition.

- \* Manual or automatic shut down.
- \* Two measurement mode: Single and Continuous
- \* Wide measuring range and high resolution.
- \* Metric/Imperial conversion.
- \* Digital backlit display gives exact reading with no guessing or errors.
- \* Can communicate with PC computer for statistics and printing by the optional cable.
- \* Can store 99 groups of measurements.
- \* Statistics is available.

### 2.SPECIFICATIONS

- Display: 4 digits LCD, backlit
- Range: 0~1250  $\mu$ m/0~50mil  
(other range may be specified)
- Resolution: 0.1  $\mu$ m (0~99.9 $\mu$ m)  
1  $\mu$ m (over 100 $\mu$ m)
- Accuracy:  $\pm 1\sim 3\%$ n or 2.5  $\mu$ m or 0.1mil  
(Whichever is the greater)
- PC interface:  
with RS-232C interface

- Power supply: 2x1.5AAA(UM-4) battery
- Operating condition:  
Temp. 0~50 $^{\circ}$ C  
Humidity <95%
- Size: 126x65x35 mm  
5.0x2.6x1.6 inch
- Weight: about 81g  
(not including batteries)

- Standard accessories:  
Carrying case .....1 pc.  
Operation manual ..... 1 pc.  
F probe in built .....1 pc.  
NF probe in built.....1 pc.  
Calibration foils .....1set.  
Substrate (Iron) .....1 pc.  
Substrate (Aluminium).....1 pc.
- Optional accessories:  
RS-232C cable & software:  
USB adaptor for RS-232C

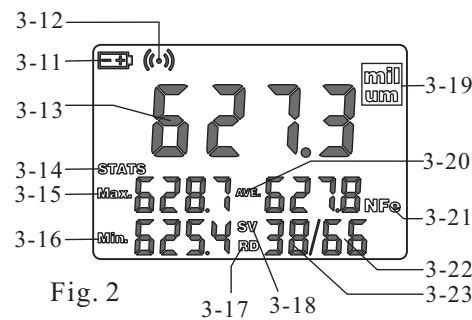

Fig. 2

- 3-11 Low Battery Indicator
- 3-12 Measuring Symbol
- 3-13 Last Reading /Browsing Value
- 3-14 Single Measurement Mode
- 3-15 Max. Indicator Value
- 3-16 Min. Indicator Value
- 3-17 Browsing State
- 3-18 Measuring State
- 3-19 Unit
- 3-20 Average Indicator
- 3-21 Substrate Indicator
- 3-22 Counter For Storing
- 3-23 Counter For Statistics

### 4.MEASURING PROCEDURE

- 4.1 Press the power key to switch on the power and '0' displays on the Display. The gauge will restore the last operation on display itself, with 'Fe' or 'NFe' symbol showed on Display. The gauge enters the auto mode which can automatically recognize the substrate itself.
- 4.2 Press the probe on a coating layer to be measured. The reading on the display is the thickness of the coating layer. The reading can be corrected by pressing the Plus key and Minus key while the probe is away from the substrate or the measurement body.
- 4.3 To take the next measurement, just lift the probe to more than 1 centimeter and then repeat the step above. The gauge can memorize the continuous measuring value automatically with statistic measurement times, Meanwhile, the

- max, min and average value will show on Display.
- 4.4 To change the measurement unit 'um' or 'mil' by Depressing Power key and not releasing it till 'UNIT' on the Display and then pressing Zero key (3-3).
- 4.5 To change measurement mode from the single to continuous or vice visa, just depressing Power key and not releasing it till 'SC' on the Display and then pressing Zero key (3-3). The symbol 'STATS' represents single mode.

### 5. STATISTICS

The gauge calculates and displays a statistical analysis of readings as they are taken.

The statistics available are:

- \* Last value
- \* Mean value marked by Ave
- \* Highest Reading marked by Max
- \* Lowest Reading marked by Min

\* Number of Readings taken

To clear the statistical data when starting a new set of data, just press and release the ZERO key. In the measurement mode marked by SV, last value could be deleted singly by pressing the 'DEL' key and re-statistics is calculated and displayed itself.

## 6. STORING AND RECALLING READINGS

6.1 Readings taken are automatically saved to the memory of the gauge. The memorized data can be browsed by pressing and releasing the 'RD' key to enter into the browsing state marked by 'READ' on the display.

6.2 In the browsing state, all the readings memorized can be recalled on the display by depressing the plus key '▲' or the minus key '▼'.

6.3 To delete singly a memorized value in the memory, just locate the reading to be deleted by the key '▲' or '▼', then press and release the key 'DEL'.

10.4 If the instrument is not to be used for any extended period, remove batteries.

## 11. CONSIDERATIONS

11.1 In order to weaken the influence of the measured material on the accuracy of measurement, it is recommended that the calibrations should be done on the uncoated material to be measured.

11.2 Probes will eventually wear. Probe life will depend on the number of measurements taken and how abrasive the coating is. Replacement separate can be fitted by qualified persons only.

## 12. RESTORE FACTORY SETTINGS

12.1 When to restore

It is recommended to restore factory settings in the one of following cases.

- A. The gauge does not measure any more.
- B. Measurement accuracy is degraded caused By environmental conditions change greatly.

12.2 How to restore?

If there is an "Err0" on the display, it indicates there is no reading to delete any more. 6.4 To quit to the measurement state, just depress the 'ZERO' key.

## 7. DELETING READINGS

7.1 To delete a reading on the display, just press the key 'DEL' no mater in the measurement state marked 'SV' or in the browsing state marked by 'RD'. Go into the browsing state by 'RD'. Go into the browsing state by pressing the 'READ' key while entering the measurement state by pressing the 'ZERO' key.

7.2 To delete all the readings in the memory, just depress the 'DEL' key in the measurement state marked by 'SV' on the display for about 4 seconds till the number of readings memorized becomes 0.

## 8. TRANSFERRING READINGS TO A COMPUTER

8.1 Install the RS232 software on your

Restore factory settings includes 'Fe' setting and 'NFe' setting. You can restore one of them or both of them respectively. Please follow procedures below to restore factory setting.

12.2.1 Please note the symbol on the display is 'Fe' or 'NFe'. If 'Fe' is on the display, the operation below is restoring the factory setting for 'Fe' type, and if 'NFe' is on the display, the operation below is restoring the factory setting for 'NFe' type.

12.2.2 Depress Power key and not release it till 'CAL' appears on the Display. It is about 12 seconds from starting depressing Power key.

12.2.3 when F:H or nF:H is on Display, lift the probe to more than 5 centimeters, then press the Zero key again and the gauge return to measurement state. The factory setting is restored. Remember, to restore setting is restored. Remember, to restore factory setting should be

PC, please always click 'the continue' button in the installing process.

8.2 Connect your gauge to your PC using the optional cable.

8.3 Switch on your gauge and ensure the Reading Screen is displayed.

8.4 Start the software and follow the instructions included with the software Demo. EXE.

## 9. CALIBRATION

9.1 Zero adjustment

Zero adjustment for 'Fe' and 'NFe' should be carried out separately. Take the iron substrate if 'Fe' on Display, while take the aluminium substrate if 'NFe' on the Display. Place the probe (3-1) on the substrate steadily. Press the zero key (3-3) and '0' will be on the Display before lifting the probe. If pressing the ZERO key but the probe is not placed on the substrate or an uncoated standard. The zero adjustment is invalid.

done within 6 seconds at every stage. Or the gauge will quit itself and restoration is invalid.

## 13. Notes

13.1 Settings includes restoring factory setting, unit setting, S/C setting, which should be done within 6 seconds at every stage, or the gauge will quit itself and keep its status before.

13.2 It is strongly recommended that no changes should be made to the value of Ln (controlled by power key, It takes about 14 seconds from starting depressing Power key. Its value can be changed by plus/minus key after displaying Ln and releasing the power key. Store its value and quit by pressing Zero key.) which will seriously affect the accuracy. Its value can be adjusted by professional persons only under the cases of replacing a new probe or making the gauge more accurate.

9.2 Select an appropriate calibration foil according to your measurement range.

9.3 Place the standard foil selected onto the substrate or the uncoated standard.

9.4 Place the sensor (3-1) mildly onto the standard foil and lift. The reading on the display is the value measured. The displayed reading value can be adjusted by pressing the plus key (3-4) or minus key (3-5) while the probe is away from the substrate or the measured body.

9.5 Repeat step 9.4 until the result is correct.

## 10. BATTERY REPLACEMENT

10.1 When it is necessary to replace the battery, i.e. battery voltage less than approx. 2.2V, the battery symbol ' ' will appear on the Display.

10.2 Slide the Battery Cover ( Fig. 1 , 3-9) away from the instrument and remove the batteries.

10.3 Install the batteries (2x1.5V AAA/UM-4) correctly into the case.

Generally, the larger the value of Ln, the smaller the reading on a same thickness. A little variation of value of Ln will cause a great change in reading at high end (e.g at 500 um/20mil). The rules to adjust the value of Ln are as follow:

- A. Reading at low end can be adjusted to the exact value by the plus or minus key.
- B. To enlarge the Ln if reading at low end (e.g at 51 um) is ok but reading at high end (e.g at 432 um) is too large. On the contrary, to decrease the Ln if reading at low end (e.g at 51 um) is ok but reading at high end (e.g at 432 um) is too small.
- C. Repeat procedures from A to B till the readings on the every standard foil are satisfying the accuracy.